

ES600 Series DC Contactor Specification



一、认证信息 Certification information

1. 符合欧盟 RoHS 指令（2011/65/EU）；
Meet RoHS (2011/65/EU);

二、产品型号含义命名 Nomenclature:

代码含义 Typical Part Number	ES	600	—	24	H	D	—	XX
➤ 产品系列 Series: ES=储能类产品								
➤ 额定电流 Continuous Current: 600=600A								
➤ 线圈电压 Coil Voltage: 24=24VDC								
➤ 触点形式 Contact Form: H=常开带辅助触点 Normal Open with Aux. Contacts								
➤ 安装方式 Mounting: D=A 型底部安装 Bottom Mount Size A								
➤ xx = 特殊定制 Special customization ; 空白 BLANK=非定制产品 conventional product								

ES600 Series DC Contactor Specification



三、技术参数 Performance Data:

主触点数据 Main Contacts Data			预期工作寿命 Expected Life	
主触点形式 Contact Arrangement	1 Form A (SPST-NO)		电耐久性(切换) Electrical Endurance(Make/Break)	600A@450VD, 1000 次
最大切换电压 Max. Switching Voltage	900VDC		机械寿命 Mechanical Life	200,000 Cycles
额定负载电流 Rated Current	600A		辅助开关参数 Aux. Contact	
最大短路电流 Max. Short Circuit Current	1000A(1.5min) 2000A(0.5min)		辅助开关触点形式 Aux. Contact Arrangement	一组常开 1 Form A
过电流能力 Short Term Current	1000A(1.5min) 2000A(0.5min)		辅助开关最大电流 Aux. Contact Current Max.	2A@30VDC/ 3A@125VAC
耐电压 Dielectric Withstandin g Voltage (Initial)	断开触点间 Between Open Contacts	3500VAC/5mA/60s	辅助开关最小电流 Aux. Contact Current Min.	100mA@8V
	线圈与触点间 Between Contacts to Coil	3500VAC/5mA/60s		
绝缘电阻 Insulation Resistance (Initial)	触点与触点间 Terminal to Terminal	Min 100 M Ω @500Vdc		
	触点与线圈间 Terminals to Coil			
触点压降 Contact Voltage Drop(initial)		Max0.5m Ω (Max50mV/100A)		
环境参数 Environmental Data			吸合 / 释放时间 Operate & Release Time	
冲击 Shock	稳定性 Functional	196m/s2 Sine half-ware pluse	吸合时间 Operate Time	20ms, Max. @20 $^{\circ}$ C
	强度 Destructive	490m/s2 Sine half-ware pluse		
工作环境温度范围 Operating Temperature		-40~+85 $^{\circ}$ C	释放时间 Release Time	10ms, Max. @20 $^{\circ}$ C
湿度 Humidity		5%~85%RH		
重量 Weight		920g \pm 10%		

备注 Note:

1.试验后不能保证产品仍然满足新产品时的耐压和绝缘电阻要求。

Do not meet dielectric & IR after the test.

2.电耐久通断比为 1s:9s

ON:OFF= 1s:9s.

ES600 Series DC Contactor Specification



3. 试验环境条件下不能导致继电器内部产生结露、结冰，否则会导致继电器失效。

The ambient environment of application should not cause any dewing or icing inside the relay. Otherwise, the relay may fail to work consequently.

四、特性 Characteristics:

线圈参数 Coil Data	
额定工作电压 Nominal Voltage	24Vdc
吸合电压 Pick-up Voltage (20°C)	≤17.5Vdc
释放电压 Drop-out Voltage (20°C)	≥12Vdc
最大启动电流 Max. Inrush Current (20°C)	0.55A
平均保持电流 Average Holding Current (20°C)	0.13A@24Vdc

五、外形尺寸与安装尺寸 Outline Dimensions : (mm)

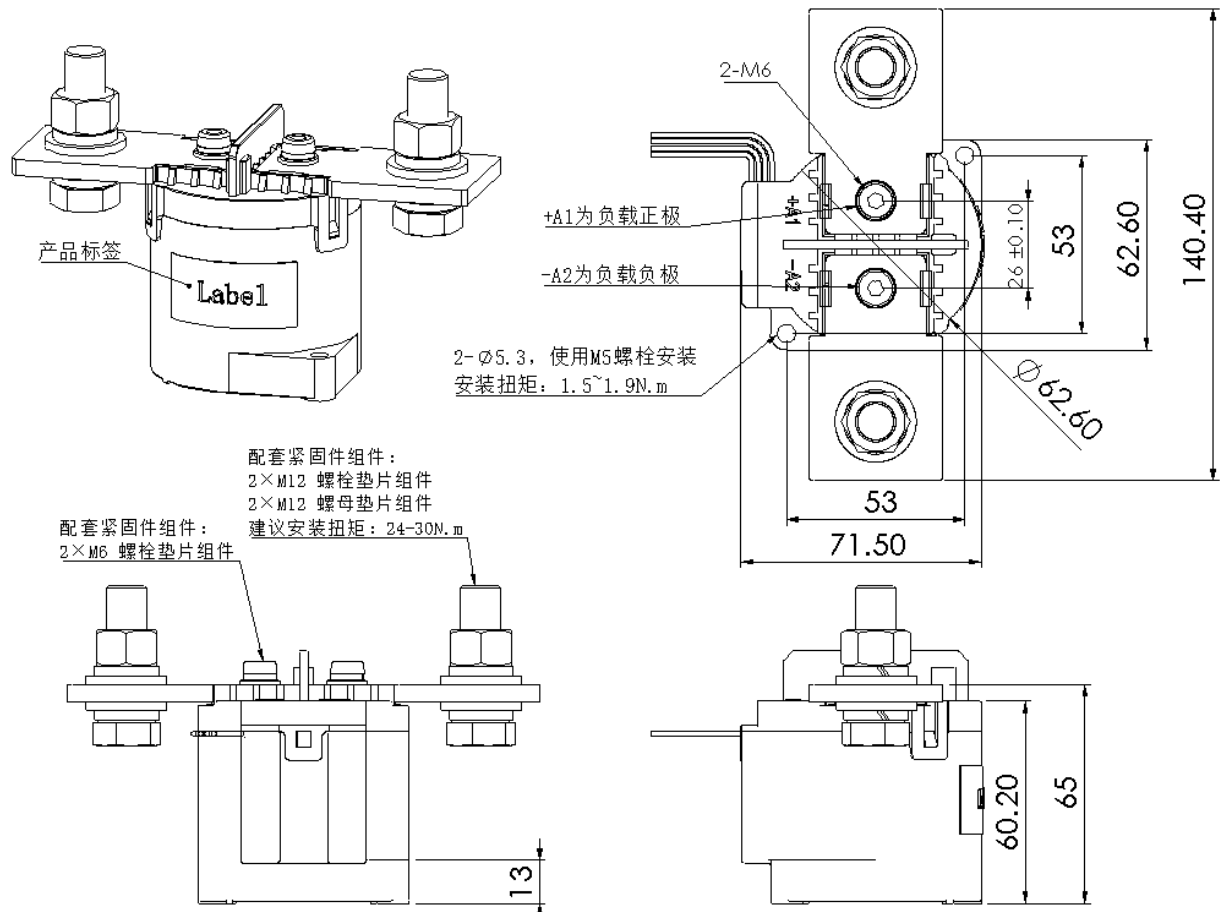

公差注释: 尺寸小于10mm±0.3, 尺寸10~50mm±0.6, 尺寸50mm以上±1.0

六、注意事项 Application Note:

1. 为防止出现松动，凡安装接触器时均要使用垫圈，使用螺钉安装时，确保垫圈厚度和强度足够，否则会变形，撑破外壳。拧紧螺母（螺柱）的扭力范围请参照样本的要求，超出扭力最大值有可能会引起产品损坏。

各个部位的螺钉锁紧扭矩请控制在下表的规定范围内。扭力值超过建议范围时可能会造成密封腔体破坏及螺纹破损。

- 铜排安装扭矩：20-30N.m
- 安装扭矩：2.3 N.m 最大

Be sure to use washer to prevent screws from loosening, all the terminals or copper bar must be in direct contact with the contactor's terminals.

Screw tightening torque is specified below. Exceeding the maximum torque can lead to product failure.

- Copper bar torque:20-30 N.m
- Mounting torque: 2.3 N.m Max.

2. 此为带线路板的产品，已经装有反向浪涌吸收电路，因此不必再使用浪涌保护器。

Products with circuit boards are already equipped with reverse surge absorption circuits, so there is no need to use surge protectors.

3. 避免把接触器安装在强磁场的环境（靠近变压器或磁铁处），同时避免将接触器靠近有热辐射的物体。

Avoid installing in a strong magnetic field (close to a transformer or magnet), or near a heat source.

4. 对继电器的线圈和触点连续通电流，电源被切断后又马上接通，此时由于线圈的温度增加，线圈的电阻会增大，从而使得产品的吸合电压升高，有可能导致超出额定吸合电压。在这种情况下，应采取以下措施：降低负载电流；限制持续通电时间或采用比额定吸合电压更高的线圈电压。

The coil and contact of the relay are continuously energized, and the power supply is cut off and immediately connected. At this time, the resistance of the coil will increase due to the increase of the temperature of the coil, so that the suction voltage of the product will increase, which may lead to the excess of the rated suction voltage. In this case, the following measures should be taken: reduce the load current; Limit continuous power or use coil voltage higher than rated suction voltage.

5. 施加在线圈两端的电压超过最大允许施加电压时，可能会因线圈温度上升而导致线圈损坏和层间短路。

When the voltage applied to both ends of the coil exceeds the maximum allowable applied voltage, the coil temperature may rise and lead to coil damage and inter-layer short circuit.

6. 触点参数中的额定值均为阻性负载时的数值。使用 $L/R > 1\text{ms}$ 的感性负载的情况下，请为该感性负载并联一个浪涌电流保护装置。未采取措施的情况下，可能会造成电气寿命下降，发生通断不良，请在设计中考虑足够的余量空间。

The rating in the contact parameters is the value at the time of the resistive load. When using an inductive load with $L/R > 1\text{ms}$, connect a surge current protection device in parallel with the inductive load. If no measures are taken, the electrical life may be degraded and the continuity may be poor. Please consider sufficient margin space in the design.

7. 产品线圈的驱动电路功率必须大于产品线圈功率，否则会降低产品的切断能力。

Drive power must be greater than coil power or it will reduce performance capability.

ES600 Series

DC Contactor Specification



8. 请不要让杂物和油污附着到主引出端；请务必保证外接端子与产品的主引出端可靠接触，否则有可能会因接触电阻过大而导致引出端温升过大。

Please do not allow debris and oil to adhere to the main lead end; Make sure that the external terminals are in reliable contact with the main outgoing end of the product, otherwise the temperature rise of the outgoing end may be too high due to the excessive contact resistance.

9. 与产品高压端相连接的引线必须有相应的电流负载能力及散热能力（建议采用 325mm² 及以上的铜排），防止发生过热影响接触器寿命。

The lead wire connected with the high voltage end of the product must have the corresponding current load capacity and heat dissipation capacity (it is recommended to use a copper bar with min 325mm²), to prevent overheating affecting the life of the contactor.

10. 此为带节能板的产品，接通电源后，约 100ms 后，电路开始自动切换，请不要在该时间段重复通断操作，否则可能会损坏接触器节能板。

After the products with energy saving panel are connected to the power supply, the circuit will automatically switch about 100ms later. Please do not repeat the on-off operation during this period, or the energy saving panel of contactor may be damaged.

12. 在接触器意外跌落的情况下，原则上请不要再使用。

Do not use if dropped.

11. SCII不可能确定继电器在每一个具体应用领域的所有性能参数，所以客户应根据自身的使用条件选择与之相匹配的产品，若有疑问，请联系SCII；但因产品选型责任仅由客户负责。

SCII is impossible to determine all the performance parameters of relays in each specific application area, Therefore, customers should choose the products matching them according to their own conditions of use. If in doubt, contact SCII; However, customer will responsible for what they chosen it is the user's responsibility to determine

12. SCII保留对产品更改的权利，客户在首次下单之前应确认此规格书内容，必要时可要求我司提供新的规格书。

SCII reserves the right to make changes. Customers should reconfirm the contents of the specification before first orders and ask for us to supply a new specification if necessary.